

FOR BOARD-TO-CABLE CONNECTION

230R SERIES (CONFORMS TO SCSI)

■ FEATURES

- 1.27 mm × 2.54 mm (0.050 in. × 0.100 in.) pitch contact arrangement enables high-density mounting.
- Cables and connectors are assembled by means of discrete wire IDC.
- Terminals are spaced in a four-row staggered arrangement (2.54 mm × 1.905 mm) (0.100 in. × 0.075 in.).
- Knife-fork two-point contacts are highly reliable.
- One-touch lock types and screw lock types are available for fixing the board-side connector and the cable-side connector.
- The following connectors conform to the SCSI standards recommended by ANSI:
 - (1) Single-operation lock types
 - 50-contact type: Conforms to the A-cable connectors prescribed in SCSI-II and SCSI-III
 - 68-contact type: Conforms to the B-cable connectors prescribed in SCSI-II
 - (2) Screw lock types
 - 68-contact type: Conforms to the P/Q-cable connectors prescribed in SCSI-III

* SCSI: Small Computer System Interface

■ SPECIFICATIONS

Item	Specifications
Operating temperature range	-55°C to +105°C
Current rating	DC 1 A
Voltage rating	AC 240 V
Contact resistance	30 mΩ max. (DC 6 V, 0.1A)
Insulation resistance	1000 MΩ min. (DC 500 V)
Dielectric withstand voltage	AC 750 V for 1 minute
Applicable wire (standard)	AWG #28 and #30 twisted-pair cables with φ 0.5 to 0.88 mm (0.020 to 0.035 in.) sheath diameter. (The applicable wires depend on the number of contacts. See the descriptions of IDC plugs and metal covers.)



■ MATERIALS

Item	Materials	
Insulator	Polyester (UL94V-0)	
Conductor	Copper alloy	
Plating	Contact	Gold plating
	Terminal	Palladium plating

230R Series (Conforms to SCSI)

STRAIGHT SOCKET (SINGLE-OPERATION LOCK TYPE)

■ DIMENSIONS

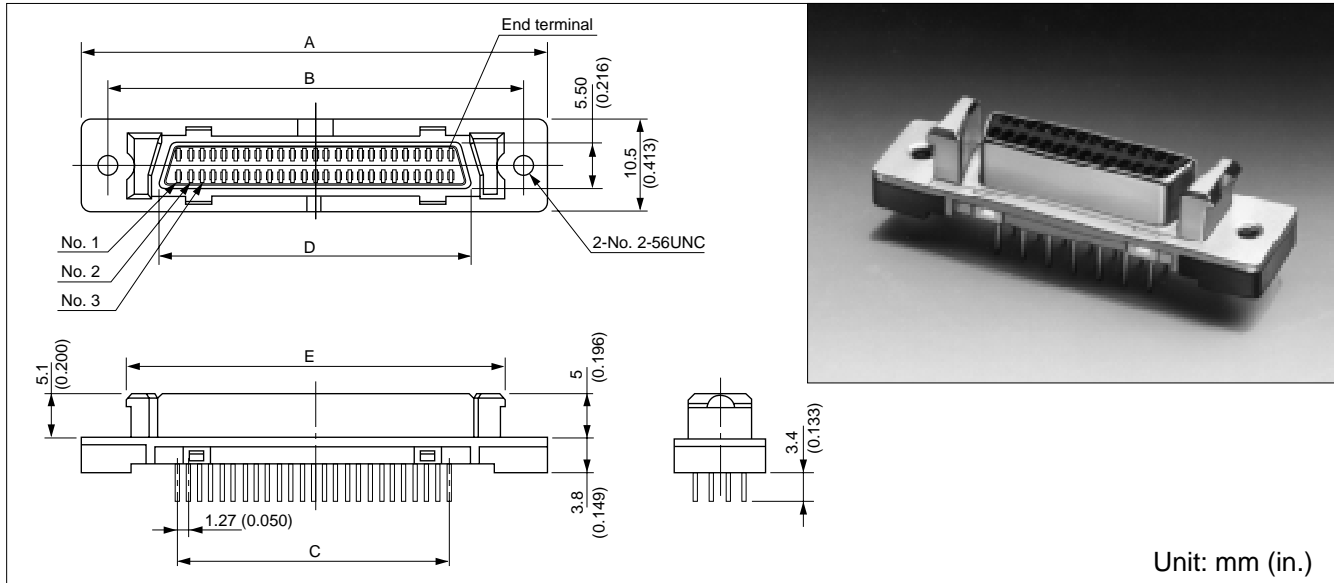

■ MOUNTING HOLE LAYOUT (COMPONENT SIDE)

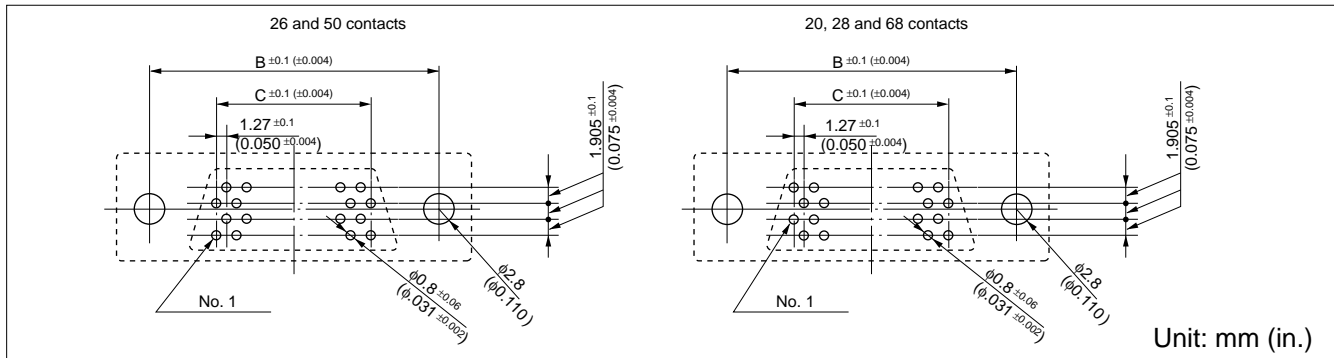

■ PATTERN INHIBITED AREAS

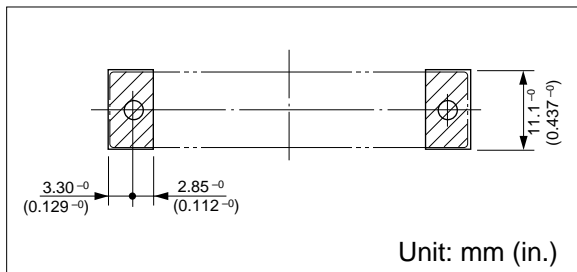

■ RECOMMENDED PANEL DIMENSIONS

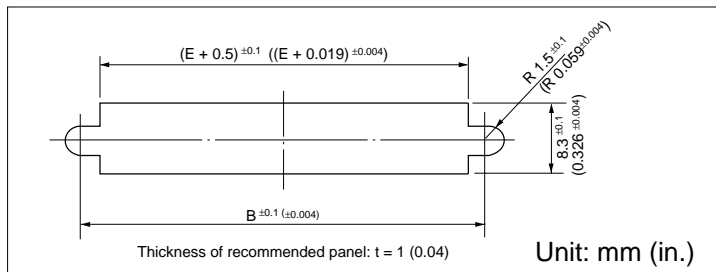

■ PART NUMBERS AND DIMENSIONS

Number of contacts	Part number	Dimensions: mm (in.)				
		A	B	C	D	E
20	FCN-234D020-G/E	33.40 (1.314)	27.43 (1.079)	11.46 (0.451)	15.60 (0.614)	23.24 (0.914)
26	FCN-234D026-G/E	37.21 (1.464)	32.24 (1.269)	15.24 (0.600)	19.41 (0.764)	27.05 (1.064)
28	FCN-234D028-G/E	38.48 (1.514)	32.51 (1.279)	16.51 (0.650)	20.68 (0.814)	28.32 (1.114)
40	FCN-234D040-G/E	46.10 (1.841)	40.13 (1.479)	24.13 (0.950)	28.30 (1.114)	35.94 (1.414)
50	FCN-234D050-G/E	52.45 (2.064)	46.48 (1.829)	30.48 (1.200)	34.65 (1.364)	42.29 (1.664)
68	FCN-234D068-G/E	63.88 (2.514)	57.91 (2.279)	41.91 (1.650)	46.08 (1.814)	53.72 (2.114)

This series includes connectors with M 2.5 threaded inserts for mounting on PC boards and panels. Specify a part number by replacing -G/E at the end with -G/C.

Example: FCN-234D050-G/C

230R Series (Conforms to SCSI)

Fujitsu Components International Headquarter Offices

Japan

Fujitsu Component Limited
Gotanda-Chuo Building
3-5, Higashigotanda 2-chome, Shinagawa-ku
Tokyo 141, Japan
Tel: (81-3) 5449-7010
Fax: (81-3) 5449-2626
Email: promothq@ft.ed.fujitsu.com
Web: www.fcl.fujitsu.com

North and South America

Fujitsu Components America, Inc.
250 E. Caribbean Drive
Sunnyvale, CA 94089 U.S.A.
Tel: (1-408) 745-4900
Fax: (1-408) 745-4970
Email: marcom@fcai.fujitsu.com
Web: www.fcai.fujitsu.com

Europe

Fujitsu Components Europe B.V.
Diamantlaan 25
2132 WV Hoofddorp
Netherlands
Tel: (31-23) 5560910
Fax: (31-23) 5560950
Email: info.marketing@fceu.fujitsu.com
Web: www.fceu.fujitsu.com

Asia Pacific

Fujitsu Components Asia Ltd.
102E Pasir Panjang Road
#04-01 Citilink Warehouse Complex
Singapore 118529
Tel: (65) 375-8560
Fax: (65) 273-3021
Email: fcal@fcal.fujitsu.com
www.fcal.fujitsu.com

© 2001 Fujitsu Components America, Inc. All company and product names are trademarks or registered trademarks of their respective owners. Rev. 09/2001